













Selection Matrix.....	2	991F Series - Heavy Duty.....	31
Stud Head Styles.....	3	991F Series - Heavy Duty.....	32
Selection Instructions.....	4	991F Series - Heavy Duty.....	33
2600/2700 Series.....	5	991F Series - Heavy Duty.....	34
2600 Series.....	6	D4002 Series - Medium Duty.....	35
2600 Series.....	7	D4002 Series - Medium Duty.....	36
2700 Series.....	8	D4002 Series - Medium Duty.....	37
2600 Series.....	9	D4002 Series - Medium Duty.....	38
2700 Series.....	10	D4002 Series - Medium Duty.....	39
2600/2700 Series.....	11	D4002 Series - Medium Duty.....	40
2600/2700 Series.....	12	D4002 Series - Medium Duty.....	41
2600/2700 Series.....	13	D4002 Series - Medium Duty.....	42
2600/2700 Series.....	14	D4002 Series - Medium Duty.....	43
15F Series.....	15	D4002 Series - Medium Duty.....	44
15F Series.....	16	AeroLoc Overview.....	45
15F Series.....	17	AeroLoc Details.....	46
50F Series - Light Duty.....	18		
50F Series - Light Duty.....	19		
50F Series - Light Duty.....	20		
50F Series - Light Duty.....	21		
50F Series - Light Duty.....	22		
50F Series - Light Duty.....	23		
50F Series - Medium Duty.....	24		
50F Series - Medium Duty.....	25		
50F Series - Medium Duty.....	26		
50F Series - Medium Duty.....	27		
50F Series - Medium Duty.....	28		
50F Series - Medium Duty.....	29		
991F Series - Heavy Duty.....	30		

How to find the suitable fastener Quarter Turn Fasteners Selection Matrix



- Zinc-plated steel finish
- ◆ Stainless steel

Upon request: (Not included in this catalogue)

- Zinc-plated steel finish

Application	Series	Tensile Strength (Test Strength) N				
			Fillister or Pan Head		Flush Head	
			Slotted Recess	Cross Recess	Slotted Recess	Cross Recess
Small Installation Size, Installation Hole Diameter Ø 5.5 - 8 mm, Highest Tensile Strength	5F	670				
	99F	700				
	50F	900				
Medium Installation Size, Installation Hole Diameter Ø 6.5 - 12.7 mm, Highest Tensile Strength	2600/2700	1330	●◆	●◆	●◆	●
	V40S	3700	○			
	50F	3700	●◆			
	4002	4700	●◆	●		
Medium Installation Size, Installation Hole Diameter Ø 13 - 17.5 mm, Highest Tensile Strength	2312	50000				
	991F	10000	○			

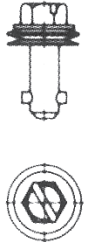
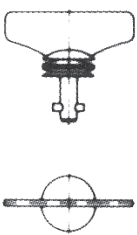
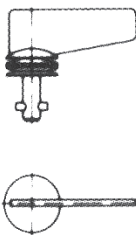
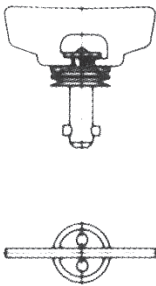
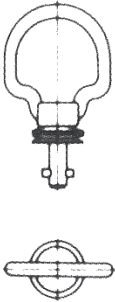
Stud Head Styles

Hex Head	Wings		Bail Handle		Knurled Knob
	Fixed	Fixed Offset	Folding	Folding	
					
○	○	○		○	○ Chrome-plated
	● ◆			○	● Chrome-plated
	●	○		○	
	● ◆			●	○
● ◆	●	●	●		

Features

Max. tensile strength 1.330 N, working load 900 N.
Small fastener giving a high tensile load.
Wide range of stud head styles and receptacles.

Selection Instructions

1. Select stud assembly and receptacle, page F-3 up to F-5, F-7 up to F-10.
2. Select stud accessories (retaining washer, gasket), page F-6 and F-7.
3. Select hex nut for receptacle, if necessary, page F-11.
4. Select stud length number from total thickness G using the formula and table on page F-2 (e.g. V26S01-*AGV).

Determining the stud length number when using receptacle:

Type 1 + 3*

$$G = P + F$$

* For Type 3: G = 9,9 mm min.

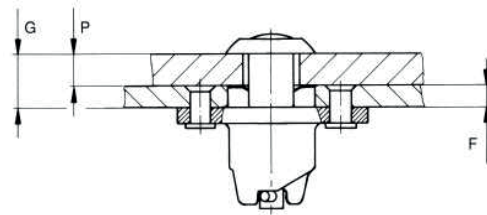

Type 2

$$G = P + F \text{ (0,75 min.)}$$

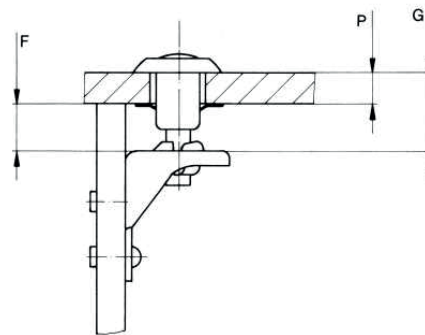

Type 4



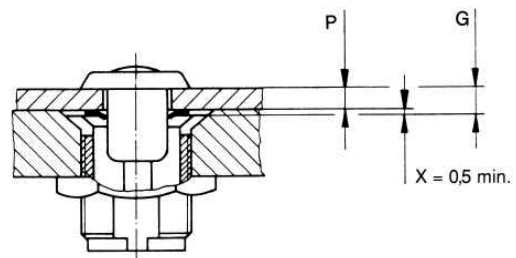



$$G = P + X \text{ (0,5 min.)}$$

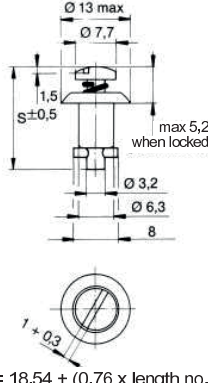

Total Thickness G	Stud Length No. When Using Type 1 Receptacles	Total Thickness G	Stud Length No. When Using Type 2 + 4 Receptacles	Total Thickness G	Stud Length No. When Using Type 3 Receptacles
0,75 - 1,50	1	0,75 - 1,50	2	9,90 - 10,65	1
1,50 - 2,30	2	1,50 - 2,30	3	10,65 - 11,40	2
2,30 - 3,05	3	2,30 - 3,05	4	11,40 - 12,20	3
3,05 - 3,80	4	3,05 - 3,80	5	12,20 - 12,95	4
3,80 - 4,60	5	3,80 - 4,60	6	12,95 - 13,70	5
4,60 - 5,35	6	4,60 - 5,35	7	13,70 - 14,50	6
5,35 - 6,10	7	5,35 - 6,10	8	14,50 - 15,25	7
6,10 - 6,85	8	6,10 - 6,85	9	15,25 - 16,00	8
6,85 - 7,60	9	6,85 - 7,60	10	16,00 - 16,75	9
7,60 - 8,40	10	7,60 - 8,40	11	16,75 - 17,50	10
8,40 - 9,15	11	8,40 - 9,15	12	17,50 - 18,30	11
9,15 - 9,90	12	9,15 - 9,90	13	18,30 - 19,05	12
9,90 - 10,65	13	9,90 - 10,65	14	19,05 - 19,80	13
10,65 - 11,40	14	10,65 - 11,40	15	19,80 - 20,60	14
11,40 - 12,20	15	11,40 - 12,20	16	20,60 - 21,35	15
12,20 - 12,95	16	12,20 - 12,95	17	21,35 - 22,10	16
12,95 - 13,70	17	12,95 - 13,70	18	22,10 - 22,85	17
13,70 - 14,50	18	13,70 - 14,50	19	22,85 - 23,60	18
14,50 - 15,25	19	14,50 - 15,25	20	23,60 - 24,40	19
15,25 - 16,00	20	15,25 - 16,00	21	24,40 - 25,15	20
16,00 - 16,75	21	16,00 - 16,75	22	25,15 - 25,90	21
16,75 - 17,50	22	16,75 - 17,50	23	25,90 - 26,65	22
17,50 - 18,30	23	17,50 - 18,30	24	26,65 - 27,40	23
18,30 - 19,05	24	18,30 - 19,05	25	27,40 - 28,20	24
19,05 - 19,80	25	19,05 - 19,80	26	28,20 - 28,95	25
19,80 - 20,60	26	19,80 - 20,60	27	28,95 - 29,70	26
20,60 - 21,35	27	20,60 - 21,35	28	29,70 - 30,50	27
21,35 - 22,10	28	21,35 - 22,10	29	30,50 - 31,25	28
22,10 - 22,85	29	22,10 - 22,85	30	31,25 - 32,00	29
22,85 - 23,60	30	22,85 - 23,60	31	32,00 - 32,75	30
23,60 - 24,40	31	23,60 - 24,40	32	32,75 - 33,50	31
24,40 - 25,15	32	24,40 - 25,15	33	33,50 - 34,30	32
25,15 - 25,90	33	25,15 - 25,90	34	34,30 - 35,05	33
25,90 - 26,65	34	25,90 - 26,65	35	35,05 - 35,80	34
26,65 - 27,40	35	26,65 - 27,40	36	35,80 - 36,60	35
27,40 - 28,20	36	27,40 - 28,20	37	36,60 - 37,35	36
28,20 - 28,95	37	28,20 - 28,95	38	37,35 - 38,10	37
28,95 - 29,70	38	28,95 - 29,70	39	38,10 - 38,85	38
29,70 - 30,50	39	29,70 - 30,50	40	38,85 - 39,60	39
30,50 - 31,25	40	29,70 - 30,50	40	39,60 - 40,40	40

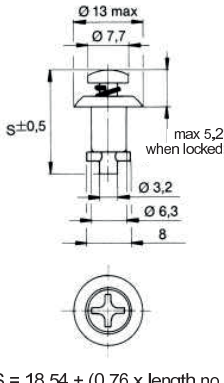

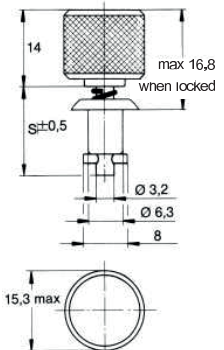

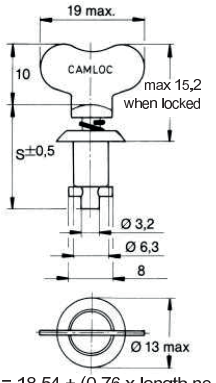
Other lengths on request.

■ Preferred dash-lengths

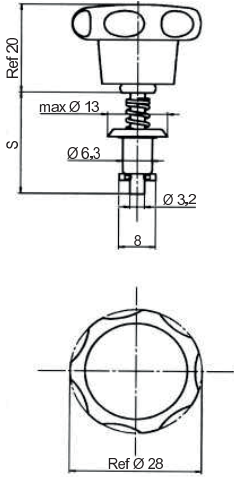

Style	Dimensions	Materials / Finish	°C	Part No.
Slotted Recess Pan Head 	 <p>$S = 18,54 + (0,76 \times \text{length no.})$</p>	Steel / zinc-plated, CrVI-free, clear passivation	120	V26S01-*AGV
		Steel / chrome-plated	120	26S38-*
		Stainless steel ¹⁾	200	2600-*S
		Steel / nickel-plated	120	26S42-*
Cross Recess Pan Head 	 <p>$S = 18,54 + (0,76 \times \text{length no.})$</p>	Steel / zinc-plated, CrVI-free, clear passivation	120	V26S02-*AGV
		Steel / nickel-plated	120	26S39-*
		Stainless steel ¹⁾	200	26S51-*
Knurled Head 	 <p>$S = 16,76 + (0,76 \times \text{length no.})$</p>	Steel / chrome-plated	120	26S34-*
Fixed Wing Head 	 <p>$S = 18,54 + (0,76 \times \text{length no.})$</p>	Steel / zinc-plated, CrVI-free, clear passivation	120	V26S04-*AGV
		Stainless steel ¹⁾	200	2600-*SW

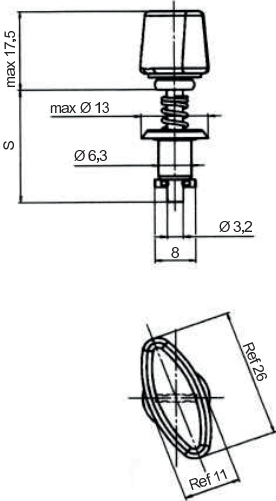
* Length no. from Table, page F-2.

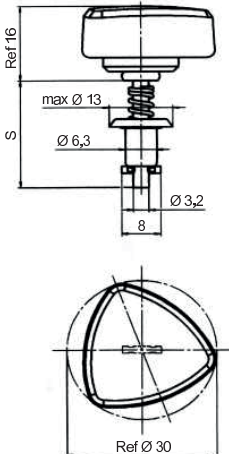
¹⁾ Max. Tensile strength 1.000 N, working load 700 N.

Style	Dimensions	Materials / Finish	°C	Part No.
<p>Star Form Head</p> 		<p>Steel / zinc-plated, CrVI-free, clear passivation with plastic knob (PA6)</p> <p>Note: Not to be used with encapsulated receptacles</p>	-40 up to +60	V26S06- *AGV
<p>Wing Head</p> 		<p>Steel / zinc-plated, CrVI-free, clear passivation with plastic knob (PA6)</p> <p>Note: Not to be used with encapsulated receptacles</p>	-40 up to +60	V26S07- *AGV
<p>Triangular Head</p> 		<p>Steel / zinc-plated, CrVI-free, clear passivation with plastic knob (PA6)</p> <p>Note: Not to be used with encapsulated receptacles</p>	-40 up to +60	V26S08- *AGV

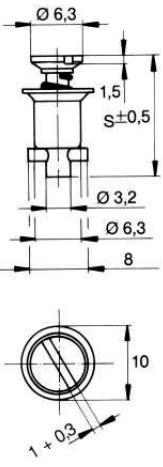

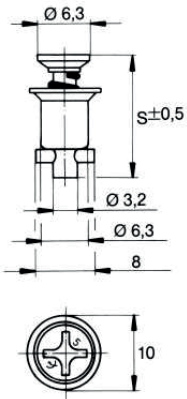
* Length no. from Table, page F-2.





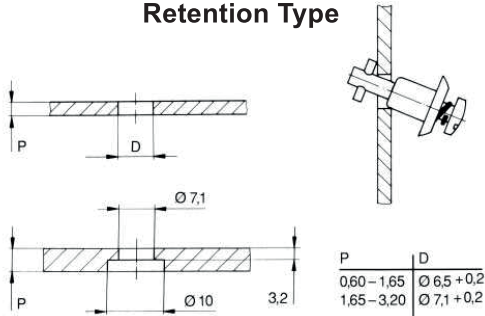
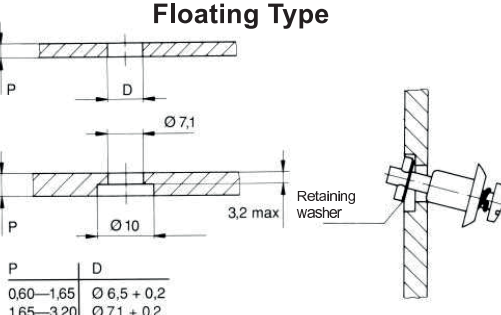
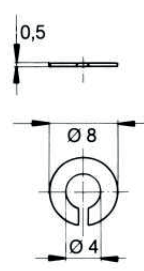
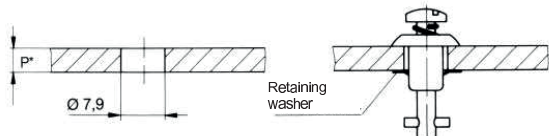
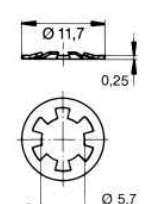
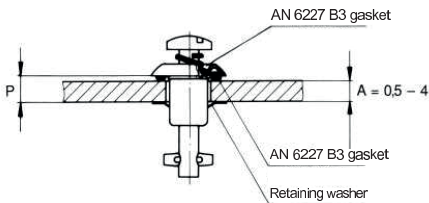
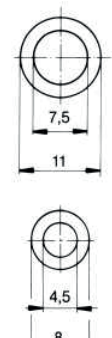

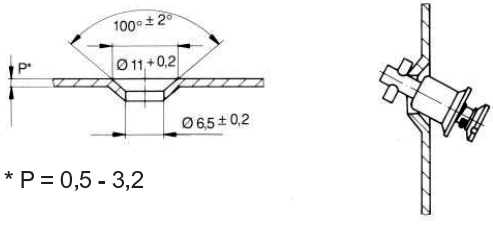
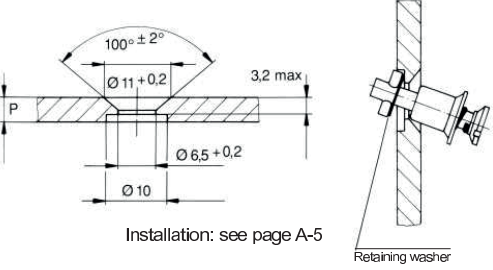
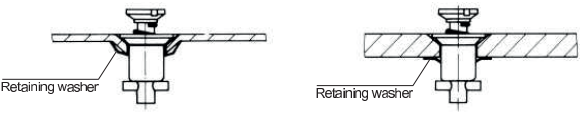
Style	Dimensions	Materials / Finish	°C	Part No.
<p>Slotted Recess Flush Head</p> 	 <p>$S = 14,73 + (0,76 \times \text{length no.})$</p>	<p>Steel / zinc-plated, CrVI-free, clear passivation</p> <p>Stainless steel ¹⁾</p>	<p>120</p> <p>200</p>	<p>V27S01-*AGV</p> <p>2700-*S</p>
<p>Cross Recess Flush Head</p> 	 <p>$S = 14,73 + (0,76 \times \text{length no.})$</p>	<p>Steel / zinc-plated, CrVI-free, clear passivation</p>	<p>120</p>	<p>V27S02-*AGV</p>

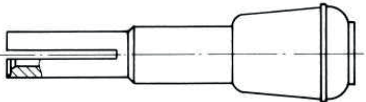

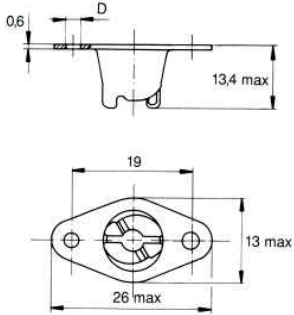
* Length no. from Table, page F-2.

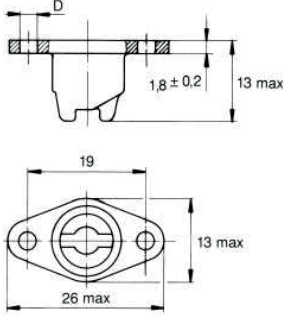

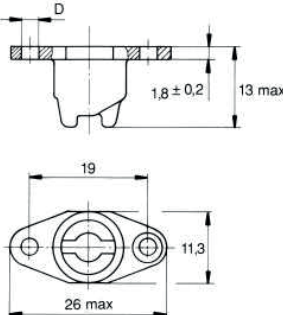
¹⁾Max. Tensile strength 1.000 N, working load 700 N.

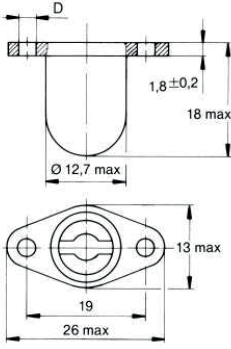
Installation Dimensions	Accessories	Material / Finish	Part No.						
<p>Stud Retention without Retaining Washer, Retention Type</p>  <table border="1" data-bbox="598 627 750 694"> <tr> <td>P</td> <td>D</td> </tr> <tr> <td>0,60–1,65</td> <td>Ø 6,5 +0,2</td> </tr> <tr> <td>1,65–3,20</td> <td>Ø 7,1 +0,2</td> </tr> </table> <p>4P3-1 installation pliers, see page F-7.</p>	P	D	0,60–1,65	Ø 6,5 +0,2	1,65–3,20	Ø 7,1 +0,2	-	<p>-</p> <p>Note: Dash "4" stud and smaller are self-captivating</p>	-
P	D								
0,60–1,65	Ø 6,5 +0,2								
1,65–3,20	Ø 7,1 +0,2								
<p>Stud Retention without Retaining Washer, Floating Type</p>  <table border="1" data-bbox="263 1030 430 1097"> <tr> <td>P</td> <td>D</td> </tr> <tr> <td>0,60–1,65</td> <td>Ø 6,5 +0,2</td> </tr> <tr> <td>1,65–3,20</td> <td>Ø 7,1 +0,2</td> </tr> </table> <p>4P3-1 installation pliers, see page F-7.</p>	P	D	0,60–1,65	Ø 6,5 +0,2	1,65–3,20	Ø 7,1 +0,2	Retaining washer	<p>Stainless steel</p> <p>Note: Retaining rings are required for stud length dash numbers "5" and up</p> 	2600-SW
P	D								
0,60–1,65	Ø 6,5 +0,2								
1,65–3,20	Ø 7,1 +0,2								
<p>Stud Retention with Retaining Washer, Fixed Spring Cup</p>  <p>*P = 0,5 - 4,75</p> <p>4P3-1 installation pliers, see page F-7.</p>	Retaining washer	<p>Stainless steel</p> <p>Not for chrome-plated parts</p> 	V2600-LW-7						
<p>Sealed</p>  <p>P = A + 0,75</p> <p>T98-1 installation tool, page F-6. Installation see page A-5.</p> <p>4P3-1 installation pliers, see page F-7.</p>	Gaskets	<p>Rubber (100°C)</p> <p>Rubber (100°C)</p> 	<p>AN6227-B6</p> <p>AN6227-B3</p>						

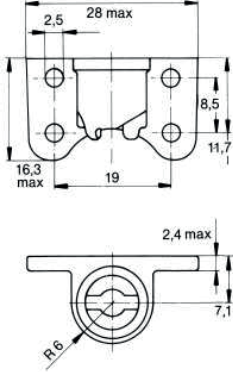

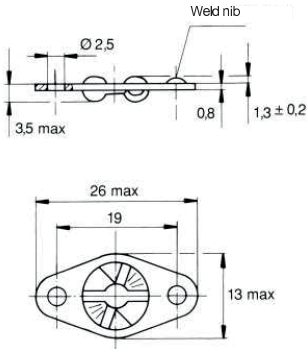
Installation Dimensions	Accessories	Material / Finish	Part No.
<p>Stud Retention without a Retaining Washer, Retention Type</p>  <p>* P = 0,5 - 3,2</p> <p>Installation tool see below</p>	-	-	-
<p>Stud Retention without a Retaining Washer, Floating Type</p>  <p>Installation: see page A-5</p> <p>Installation tool see below</p>	Retaining washer	Stainless steel	2600-SW
<p>Stud Retention with a Retaining Washer, Fixed Spring Cup</p>  <p>Installation: see page A-5</p> <p>Installation tool see below</p>	Retaining washer	Stainless steel Steel / nickel-plated	V2600-LW-7 V27W01-1AN
	Stud Installation pliers		4P3-1
	V2600-LW-7 retaining washer installation tool		T98-1

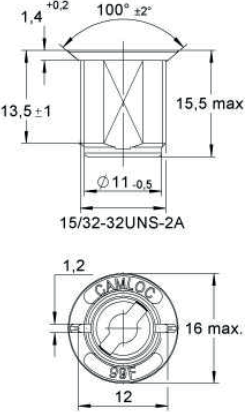
Style	Dimensions	Materials / Finish	D	°C	Part No.
Type 1 Lightweight 		Steel / zinc-plated, CrVI-free, clear passivation	2,6	120	V26R6-1AGV
Type 1 Cast 		Hard bronze / zinc-plated, CrVI-free, clear passivation Hard bronze / zinc-plated, CrVI-free, clear passivation Stainless steel	2,5 3,3 2,5	120 120 200	V212-12-1FGV V212-12-2FGV 212-12S
Type 1 Narrow Width 		Hard bronze / zinc-plated, CrVI-free, clear passivation	2,5	120	V212-12N-1FGV
Type 1 Encapsulated 		Hard bronze / zinc-plated, CrVI-free, clear passivation Capsule: Steel / zinc-plated, CrVI-free, clear passivation Stainless steel	2,5 2,5	120 150	26R16-1FGV 26R18-1-1AA

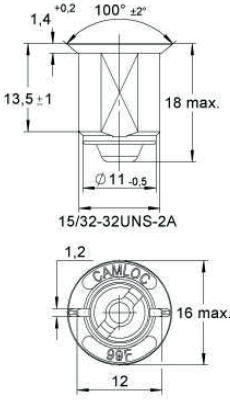
Style	Dimensions	Materials / Finish	°C	Part No.
<p>Type 2 Side Mounting</p> 		Aluminium / anodized	175	26R1-1
<p>Type 3 Rivet / Screw or Weld Mounting</p> 		<p>Rivet / Screw Mounting Steel / zinc-plated, CrVI-free, clear passivation</p> <p>Stainless steel</p> <p>Welding Stainless steel</p>	<p>120</p> <p>200</p> <p>-</p>	<p>V312-12AGV</p> <p>312-12S</p> <p>312-12WS</p>

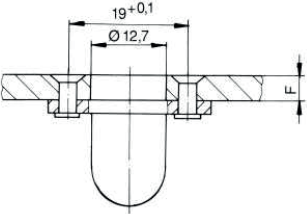
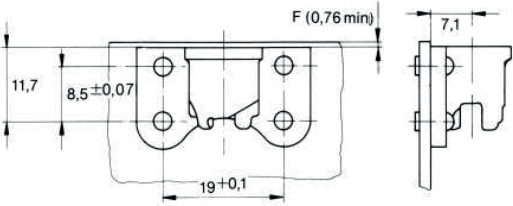
Style	Dimensions	Materials / Finish	°C	Part No.
<p>Type 4 Single Hole Mounting</p> 		<p>Zinc die cast / zinc-plated, CrVI-free, clear chromate</p>	<p>100</p>	<p>99R10-01A1</p>
<p>Type 4 Single Hole Mounting Encapsulated</p> 		<p>Zinc die cast / zinc-plated, CrVI-free, clear chromate</p> <p>Capsule: Stainless steel</p>	<p>100</p>	<p>99E10-01</p>

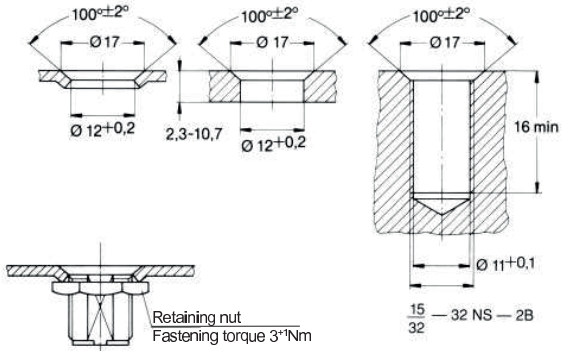
Installation Dimensions	
Type 1 + 3 Receptacles Hole Pattern	
	
Type 2 Receptacle Hole Pattern (Side Mounting)	
	

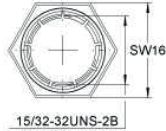
Installation Dimensions	Accessories	Materials / Finish	Part No.
<p style="text-align: center;">Installation Options Type 4 Receptacle</p>  <p style="text-align: right;">Retaining nut Fastening torque 3[*]Nm</p>	<p>Retaining nut</p>  <p>Tap</p> 	<p>Steel / zinc-plated, CrVI-free, clear chromate</p>	<p>99N10-01A1</p> <p>15/32-32NS-2B</p>

Features

Max. tensile strength 1.330 N, working load 930 N.
 Quick opening and closing by a push of the finger.
 Easy installation with single hole mounting.

Selection Instructions

1. Select stud assembly, page K-2 and receptacle, page K-3.
2. Select retaining washer, page K-2 and retaining hexnut, page K-3, if necessary.
3. Select stud length number from Panel thickness P using the table below, insert into stud part number * (e.g. 15S1-*-1AD).

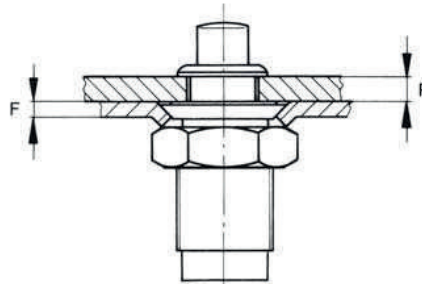

Stud Length Table

Panel Thickness P	Stud Length No.
0,7 - 2,3	1
2,3 - 3,8	3
3,8 - 5,3	5
5,3 - 6,9	7
6,9 - 8,4	9
8,4 - 9,9	11
9,9 - 11,4	13
11,4 - 13,0	15

Other lengths on request.

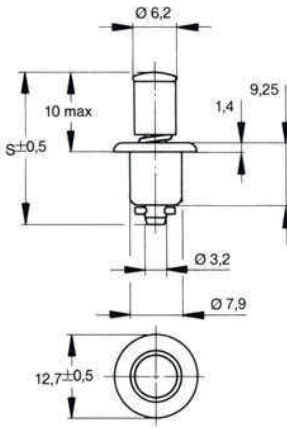

■ Preferred dash-lengths

Style	Dimensions	Materials / Finish	°C	Part No.
	 <p style="text-align: center;">S=22,4 + (0,76 x length no.)</p>	Steel / nickel-plated	120	15S1- *-1AD
		Steel / zinc-plated CrVI-free, clear passivation	120	15S1- *-1AJ

* Length no. from Table, see page K-1.

Other lengths and surfaces can be ordered upon request.

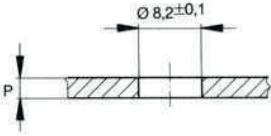
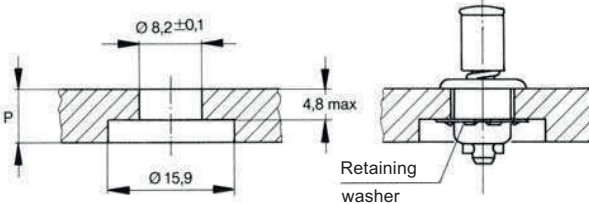
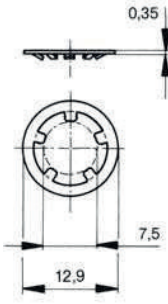
Stud Installation Instructions

Installation Dimensions	Accessories	Materials / Finish	Part No.
<p>Panel thickness up to 4,8</p>  <p>Panel thickness from 4,8 + up</p> 	<p>Retaining washer</p> 	Stainless steel	15S11-1CJ
	<p>Installation Tool for 15S11-1CJ retaining washer</p>		T107-1

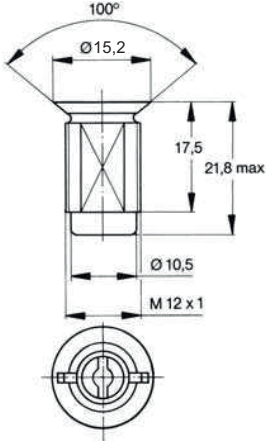
Style	Dimensions	Materials / Finish	°C	Part No.
		Zinc die casting / zinc-plated CrVI-free, clear passivation	120	V15R13-1-1AB

Receptacle Installation Instructions

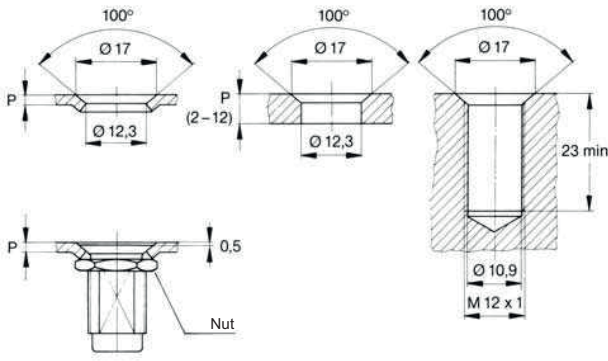
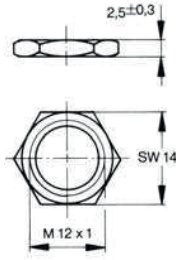
Installation Dimensions	Accessories	Materials / Finish	Part No.
	<p>Hex Nut</p> 	Steel / zinc-plated, CrVI-free, clear passivation	V15R14-1-1AB

Features

- Max. tensile strength 900 N, working load 650 N.
- Stud assembly incorporates a plastic washer to protect decorative surfaces.
- Snap-in or clip-on spring loaded receptacle.
- Snap-in grommet for quick stud installation without a retaining washer.

Selection Instructions

1. Select stud assembly and receptacle, page D-2 to D-4 and D-6.
2. Select retaining washer or grommet, page D-5.
3. Select stud length number from total thickness G using the formula and table below (e.g. 50E21-*AGV).

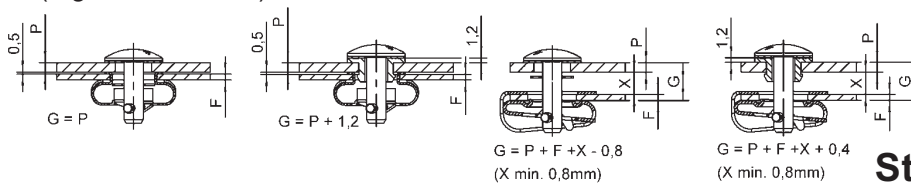





Stud Length Table



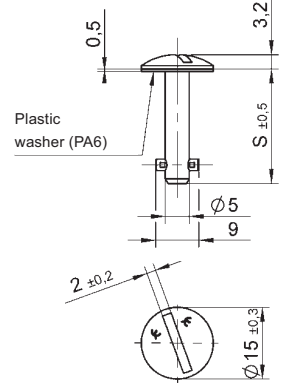

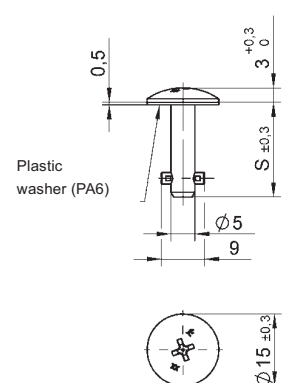
Total Thickness G	Stud Length No. when using Receptacles Type 1 F= 1,0 - 2,1	Total Thickness G	Stud Length No. when using Receptacles Type 2 F= 2,1 - 3,0	Total Thickness G	Stud Length No. when using Receptacles Type 3
0,50 - 1,10	5	0,50 - 1,10	7	2,30 - 2,90	5
1,10 - 1,70	6	1,10 - 1,70	8	2,90 - 3,50	6
1,70 - 2,30	7	1,70 - 2,30	9	3,50 - 4,10	7
2,30 - 2,90	8	2,30 - 2,90	10	4,10 - 4,70	8
2,90 - 3,50	9	2,90 - 3,50	11	4,70 - 5,30	9
3,50 - 4,10	10	3,50 - 4,10	12	5,30 - 5,90	10
4,10 - 4,70	11	4,10 - 4,70	13	5,90 - 6,50	11
4,70 - 5,30	12	4,70 - 5,30	14	6,50 - 7,10	12
5,30 - 5,90	13	5,30 - 5,90	15	7,10 - 7,70	13
5,90 - 6,50	14	5,90 - 6,50	16	7,70 - 8,30	14
6,50 - 7,10	15	6,50 - 7,10	17	8,30 - 8,90	15
7,10 - 7,70	16	7,10 - 7,70	18	8,90 - 9,50	16
7,70 - 8,30	17	7,70 - 8,30	19	9,50 - 10,10	17
8,30 - 8,90	18	8,30 - 8,90	20	10,10 - 10,70	18
8,90 - 9,50	19	8,90 - 9,50	21	10,70 - 11,30	19
9,50 - 10,10	20	9,50 - 10,10	22	11,30 - 11,90	20
10,10 - 10,70	21	10,10 - 10,70	23	11,90 - 12,50	21
10,70 - 11,30	22	10,70 - 11,30	24	12,50 - 13,10	22
11,30 - 11,90	23	11,30 - 11,90	25	13,10 - 13,70	23
11,90 - 12,50	24	11,90 - 12,50	26	13,70 - 14,30	24
12,50 - 13,10	25	12,50 - 13,10	27	14,30 - 14,90	25
13,10 - 13,70	26	13,10 - 13,70	28	14,90 - 15,50	26
13,70 - 14,30	27	13,70 - 14,30	29	15,50 - 16,10	27
14,30 - 14,90	28	14,30 - 14,90	30	16,10 - 16,70	28
14,90 - 15,50	29	14,90 - 15,50	31	16,70 - 17,30	29
15,50 - 16,10	30	15,50 - 16,10	32	17,30 - 17,90	30

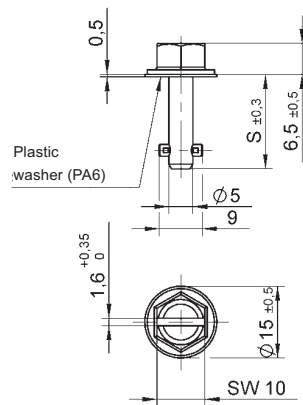
Other lengths on request.



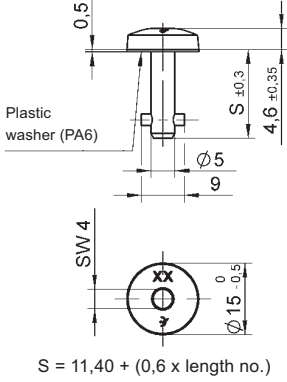

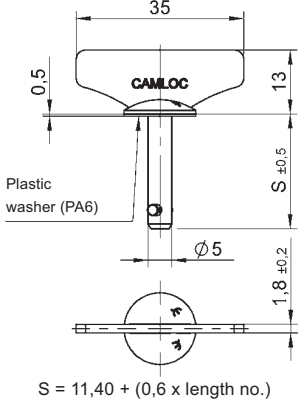
■ Preferred dash-lengths

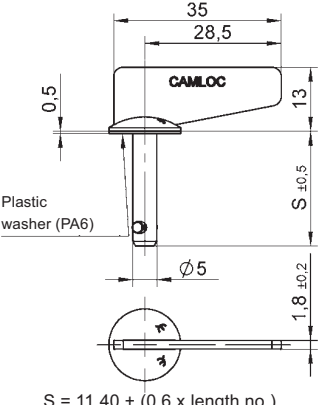
Style	Dimensions	Materials / Finish	°C	Part No.
<p>Slotted Recess Head</p> 	 <p>S = 11,40 + (0,6 x length no.)</p>	<p>Steel / zinc-plated, CrVI-free, clear passivation with plastic washer (PA6)</p> <p>Stainless steel with plastic washer (PA6)</p>	<p>80</p> <p>80</p>	<p>50E21-*AGV</p> <p>50E21-*S</p>
<p>Cross Recess Head</p> 	 <p>S = 11,40 + (0,6 x length no.)</p>	<p>Steel / zinc-plated, CrVI-free, clear passivation with plastic washer (PA6)</p>	<p>80</p>	<p>50E70-*AGV</p>
<p>Hex Head Slotted Recess</p> 	 <p>S = 11,40 + (0,6 x length no.)</p>	<p>Steel / zinc-plated, CrVI-free, clear passivation with plastic washer (PA6)</p>	<p>80</p>	<p>50E90-*AGV</p>

* Length no. from Table, see page D-1.

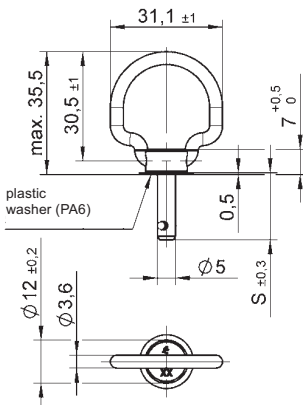

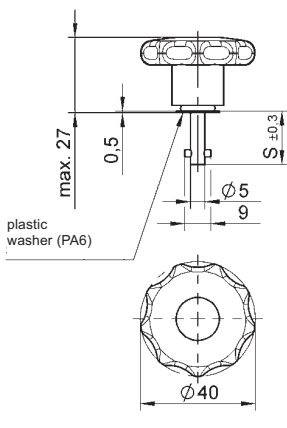
Style	Dimensions	Materials / Finish	°C	Part No.
<p>Hex Recess Head</p> 	 <p>S = 11,40 + (0,6 x length no.)</p>	Steel / zinc-plated, CrVI-free, clear passivation with plastic washer (PA6)	80	50E60-*AGV
<p>Fixed Wing Head</p> 	 <p>S = 11,40 + (0,6 x length no.)</p>	Steel / zinc-plated, CrVI-free, clear passivation with plastic washer (PA6) Stainless steel with plastic washer (PA6)	80 80	50E21-*WAGV 50E21-*WS
<p>Offset Fixed Wing Head</p> 	 <p>S = 11,40 + (0,6 x length no.)</p>	Steel / zinc-plated, CrVI-free, clear passivation with plastic washer (PA6)	80	50E21-*W0AGV

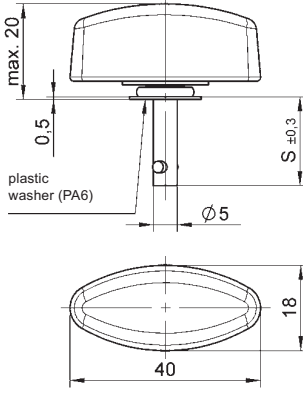
* Length no. from Table, see page D-1.

Style	Dimensions	Materials / Finish	°C	Part No.
<p>Folding Bail Handle</p> 		Steel / zinc-plated, CrVI-free, clear passivation with plastic washer (PA6)	80	50E18-*AGV
<p>Plastic Star Form Head</p> 		<p>Steel / zinc-plated, CrVI-free, clear passivation with plastic head and plastic washer (PA6)</p> <p>Stainless steel with plastic head and plastic washer (PA6)</p>	<p>- 40 up to + 60</p> <p>- 40 up to + 60</p>	<p>50E80-*AGV</p> <p>50E80-*CP</p>
<p>Plastic Wing Head</p> 		<p>Steel / zinc-plated, CrVI-free, clear passivation with plastic head and plastic washer (PA6)</p> <p>Stainless steel with plastic head and plastic washer (PA6)</p>	<p>- 40 up to + 60</p> <p>- 40 up to + 60</p>	<p>50E82-*AGV</p> <p>50E82-*CP</p>

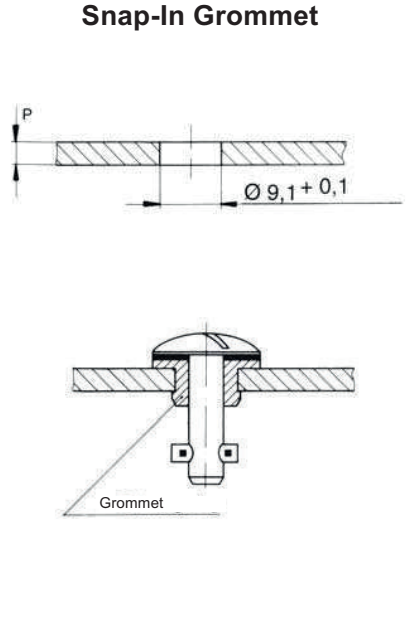
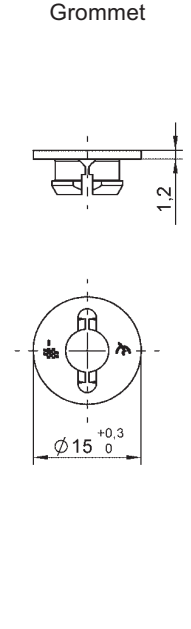
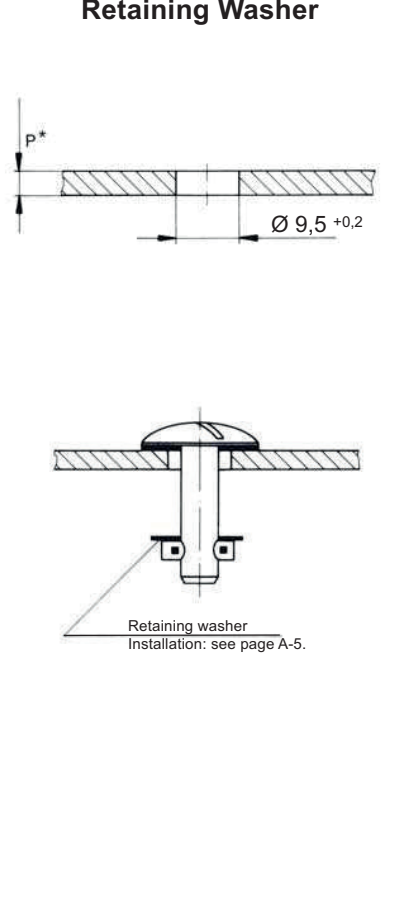
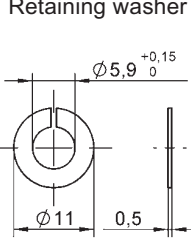
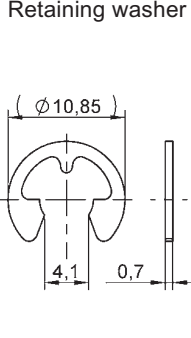
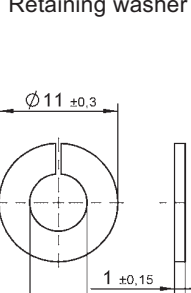
* Length no. from Table, see page D-1.

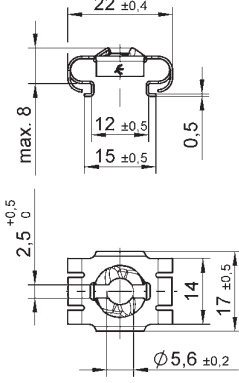
Style	Dimensions	Materials / Finish	P	Part No.		
<p>Snap-In Grommet</p> 	<p>Grommet</p> 	<p>Plastic (PA6) / natural colour</p> <p>Working temperature: -40°C + 100°C</p>	Up to 1,60	50S12-0-1AA		
			1,70 - 2,80	50S12-1-1AA		
			2,90 - 4,00	50S12-2-1AA		
			4,10 - 5,30	50S12-3-1AA		
			5,40 - 6,65	50S12-4-1AA		
<p>Retaining Washer</p> 	<p>Retaining washer</p> 	<p>Stainless steel</p>		4002-SW-SS		
			<p>Retaining washer</p> 	<p>Stainless steel</p>		50E2-3BP
			<p>Retaining washer</p> 	<p>Plastic (PA6) / natural colour</p> <p>Working temperature: -40°C + 120°C</p> <p>ADVANTAGE: Plastic retaining washer can be assembled without tooling</p>		50W204-01K
<p>*For P up to 2mm Ø 8 +0,2 for installation without retaining washer</p>						

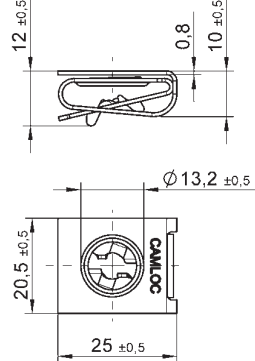
Style	Dimensions	Materials / Finish	Panel Thickness P	°C	Part No.
Snap-In 		Spring steel / zinc-flake coated	F = 1,0 - 2,0	170	50E20-1AK7 (Type 1)
		Spring steel / zinc-flake coated	F = 2,1 - 3,0	170	50E20-2AK7 (Type 2)
Clip-On 		Spring steel / zinc-flake coated	F = 0,8 - 5,6	170	V50R4-2-1AK7 (Type 3)

Receptacle Installation Instructions

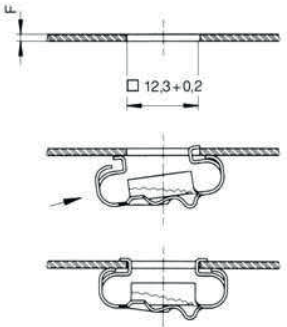
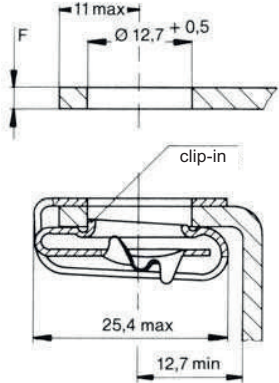
Installation Dimensions	
Snap-In 	Clip-On 

Features

- Max. tensile strength 3.700 N, working load 2.600 N.
- Small fastener giving high tensile load.
- Flat receptacle.
- High preload.

Selection Instructions

1. Select stud assembly and receptacle, page E-2 to E-4 and E-6.
2. Select retaining washer, page E-5.
3. Select stud length number from total thickness G using the formula and table below (e.g. 50E8-*AGV).

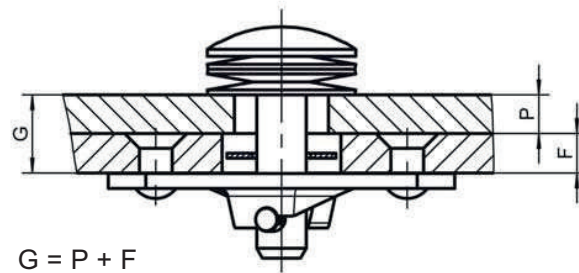





Stud Length Table

Total Thickness G	Stud Length No.
0,50 - 1,10	2
1,10 - 1,70	3
1,70 - 2,30	4
2,30 - 2,90	5
2,90 - 3,50	6
3,50 - 4,10	7
4,10 - 4,70	8
4,70 - 5,30	9
5,30 - 5,90	10
5,90 - 6,50	11
6,50 - 7,10	12
7,10 - 7,70	13
7,70 - 8,30	14
8,30 - 8,90	15
8,90 - 9,50	16
9,50 - 10,10	17
10,10 - 10,70	18

Total Thickness G	Stud Length No.
10,70 - 11,30	19
11,30 - 11,90	20
11,90 - 12,50	21
12,50 - 13,10	22
13,10 - 13,70	23
13,70 - 14,30	24
14,30 - 14,90	25
14,90 - 15,50	26
15,50 - 16,10	27
16,10 - 16,70	28
16,70 - 17,30	29
17,30 - 17,90	30
17,90 - 18,50	31
18,50 - 19,10	32
19,10 - 19,70	33
19,70 - 20,30	34
20,30 - 20,90	35

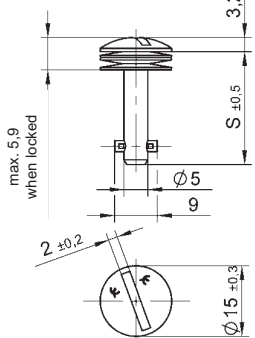

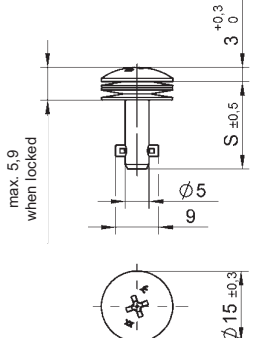

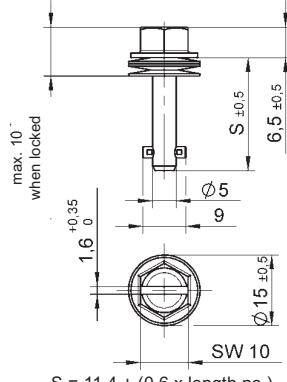
Other lengths on request.

■ Preferred dash-lengths

Style	Dimensions	Materials / Finish	°C	Part No.
Slotted Recess Head 	 <p>$S = 11,4 + (0,6 \times \text{length no.})$</p>	Steel / zinc-plated, CrVI-free, clear passivation Stainless steel ¹⁾	120 200	50E8-*AGV 50E8-*S
Cross Recess Head 	 <p>$S = 11,4 + (0,6 \times \text{length no.})$</p>	Steel / zinc-plated, CrVI-free, clear passivation	120	50E71-*AGV
Hex Head Slotted Recess 	 <p>$S = 11,4 + (0,6 \times \text{length no.})$</p>	Steel / zinc-plated, CrVI-free, clear passivation	120	50E91-*AGV

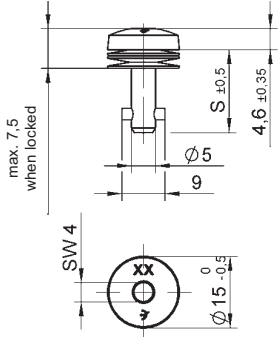

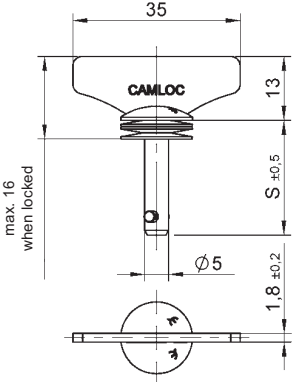

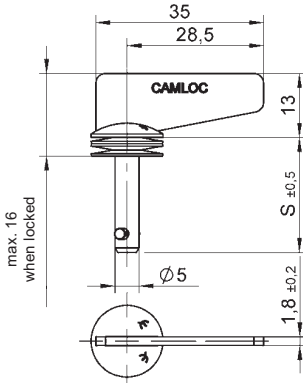

* Length no. from Table, page E-1.

¹⁾ Max. tensile strength 2.600 N, working load 1.700 N.

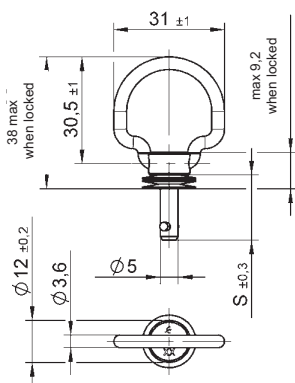
Style	Dimensions	Materials / Finish	°C	Part No.
<p>Hex Recess Head</p> 	 <p>$S = 11,4 + (0,6 \times \text{length no.})$</p>	Steel / zinc-plated, CrVI-free, clear passivation	120	50E61-*AGV
<p>Fixed Wing Head</p> 	 <p>$S = 11,4 + (0,6 \times \text{length no.})$</p>	Steel / zinc-plated, CrVI-free, clear passivation Stainless steel ¹⁾	120 200	50E8-*WAGV 50E8-*WS
<p>Offset Fixed Wing Head</p> 	 <p>$S = 11,4 + (0,6 \times \text{length no.})$</p>	Steel / zinc-plated, CrVI-free, clear passivation	120	50E8-*W0AGV

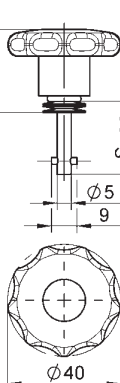
* Length no. from Table, page E-1.

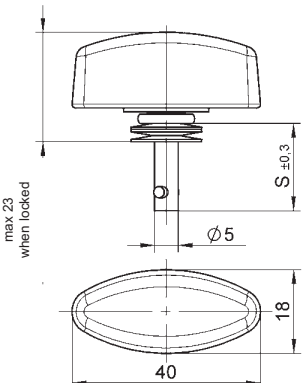
¹⁾Max. tensile strength 2.600 N, working load 1.700 N.

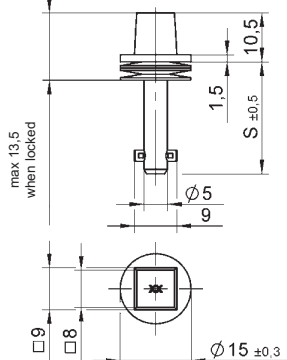
Style	Dimensions	Materials / Finish	°C	Part No.
Folding Bail Handle 		Steel / zinc-plated, CrVI-free, clear passivation	120	50E19-*AGV
Star Form Head 		Steel / zinc-plated, CrVI-free, clear passivation with plastic knob (PA 6) Stainless steel ¹⁾ with plastic knob	-40 up to +60 -40 up to +60	50E81-*AGV 50E81-*CP
Wing Head 		Steel / zinc-plated, CrVI-free, clear passivation with plastic knob (PA 6) Stainless steel ¹⁾ with plastic knob	-40 up to +60 -40 up to +60	50E83-*AGV 50E83-*CP
Square Head 		Steel / zinc-plated, CrVI-free, clear passivation	120	50E7-*AGV

* Length no. from Table, page E-1.

¹⁾Max. tensile strength 2.600 N, working load 1.700 N.

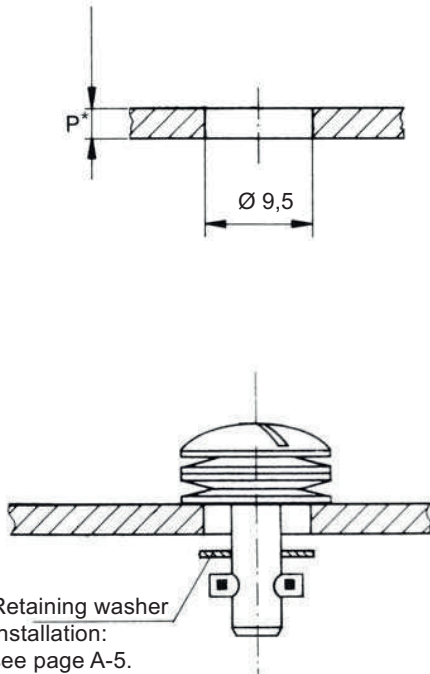
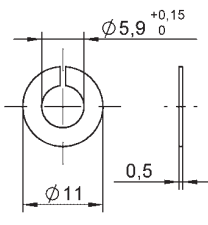
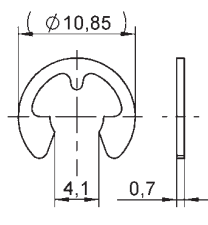
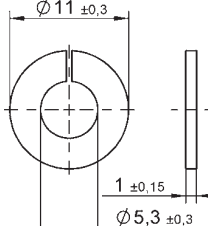
Installation Dimensions	Accessories	Material / Finish	Part No.
 <p>Retaining washer Installation: see page A-5.</p>	<p>Retaining washer (loose)</p> 	Stainless steel	4002-SW-SS
	<p>Retaining washer (fixed)</p> 	Stainless steel	50E2-3BP
	<p>Retaining washer (loose)</p> 	<p>Plastic (PA6) / natural colour</p> <p>Working temperature: -40°C + 120°C</p> <p>ADVANTAGE: Plastic retaining washer to be assembled without tooling.</p>	50W204-01K

*For P up to 2 mm $\varnothing 8^{+0.2}$ for installation without retaining washer

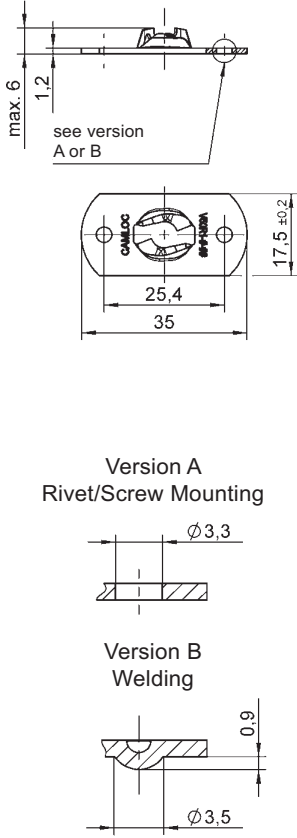
Style	Dimensions	Materials / Finish	°C	Part No.
Rivet- / Screw or Weld Mounting 	 <p>max. 6 1.2 see version A or B</p> <p>Version A Rivet/Screw Mounting Ø 3,3</p> <p>Version B Welding 0.9 Ø 3,5</p>	Rivet / Screw Mounting Steel / zinc-plated, CrVI-free, clear passivation	120	V50R3-1-1AGV
		Stainless steel	200	V50R3-1-1BP
		Welding Steel / zinc-plated	-	V50R3-1-2AZ
		Steel / oil coated	-	V50R3-1-2AR

Receptacle Installation Instructions

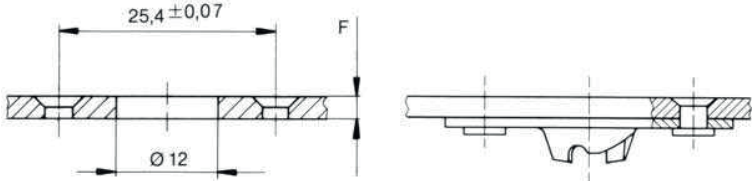
Installation Dimensions
Rivet- / Screw or Weld Mounting 

Features

Max. tensile strength 10.000 N, working load 7.000 N.

High tensile strength and preload.

Typical applications:

Commercial vehicles, coaches, agricultural machinery, chemical engineering, heating systems etc.

1. Select stud assembly and receptacle, pages H-2, H-3 and H-5.
2. Sealed: Also select rubber gasket and buffer plate, page H-4.
3. Select retaining washer, page H-4.
4. Select stud length number from total thickness G using the formula and table below (e.g. 991S01-*AGV).

Determining the stud length number when using:

Rivet, Screw and Weld Mounting Receptacle

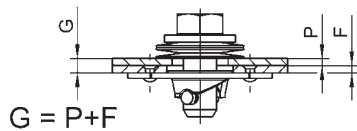

Sealed Stud Assemblies

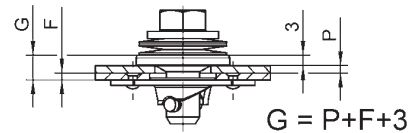

Clip-On Receptacle

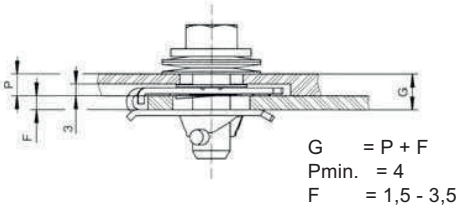





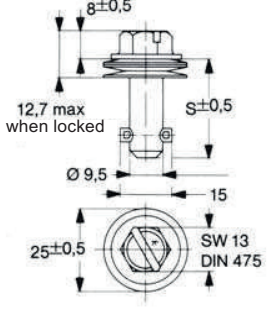

Stud Length Table

Total Thickness G	Stud Length No.	Total Thickness G	Stud Length No.	Total Thickness G	Stud Length No.
0,90 - 1,65	1	13,85 - 14,60	18	26,80 - 27,55	35
1,65 - 2,40	2	14,60 - 15,35	19	27,55 - 28,30	36
2,40 - 3,15	3	15,35 - 16,15	20	28,30 - 29,10	37
3,15 - 3,95	4	16,15 - 16,90	21	29,10 - 29,85	38
3,95 - 4,70	5	16,90 - 17,65	22	29,85 - 30,60	39
4,70 - 5,45	6	17,65 - 18,40	23	30,60 - 31,35	40
5,45 - 6,20	7	18,40 - 19,20	24	31,35 - 32,15	41
6,20 - 7,00	8	19,20 - 19,95	25	32,15 - 32,90	42
7,00 - 7,75	9	19,95 - 20,70	26	32,90 - 33,65	43
7,75 - 8,50	10	20,70 - 21,45	27	33,65 - 34,40	44
8,50 - 9,25	11	21,45 - 22,25	28	34,40 - 35,20	45
9,25 - 10,05	12	22,25 - 23,00	29	35,20 - 35,95	46
10,05 - 10,80	13	23,00 - 23,75	30	35,95 - 36,70	47
10,80 - 11,55	14	23,75 - 24,50	31	36,70 - 37,45	48
11,55 - 12,30	15	24,50 - 25,25	32	37,45 - 38,25	49
12,30 - 13,10	16	25,25 - 26,05	33	38,25 - 39,00	50
13,10 - 13,85	17	26,05 - 26,80	34		

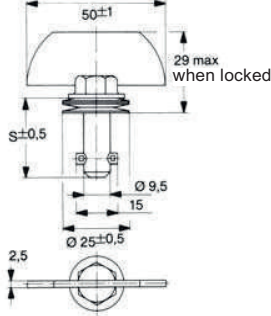

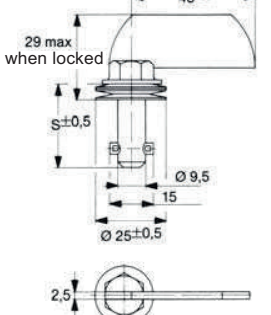
Other lengths on request.

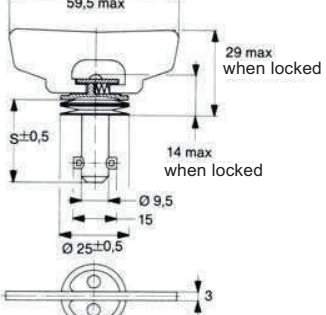
■ Preferred dash-lengths

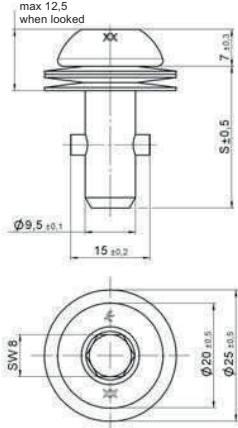

Style	Dimensions	Materials / Finish	°C	Part No.
Hex Head Slotted Recess 	 <p>$S = 16,26 + (0,76 \times \text{length no.})$</p>	Steel / zinc-plated, CrVI-free, clear passivation Stainless steel ¹⁾	120 200	991S01- *-1AGV 991S01- *-1BP
Fixed Wing Head 	 <p>$S = 16,26 + (0,76 \times \text{length no.})$</p>	Steel / zinc-plated, CrVI-free, clear passivation	120	991S02- *-1AGV
Offset Fixed Wing Head 	 <p>$S = 16,26 + (0,76 \times \text{length no.})$</p>	Steel / zinc-plated, CrVI-free, clear passivation	120	991S03- *-1AGV
180° Folding Wing Head 	 <p>$S = 16,26 + (0,76 \times \text{length no.})$</p>	Steel / zinc-plated, CrVI-free, clear passivation	120	991S05- *-1AGV

* Length no. from Table, see page H-1.

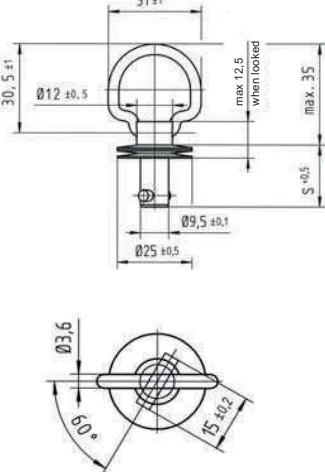
¹⁾ Max. tensile strength 7.000 N, working load 4.500 N.

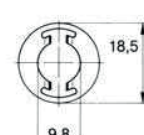
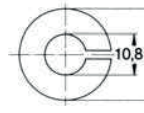

Style	Dimensions	Materials / Finish	°C	Part No.
<p>Hex Recess Head</p> 		Steel / zinc-plated, CrVI-free, clear passivation	120	991S30-*AGV
<p>Folding Bail Handle</p> 	 <p>S = 15,03 + (0,76 X length no.)</p>	Steel / zinc-plated, CrVI-free, clear passivation	120	991S2991-*AGV

* Length no. from Table, see page H-1.

Installation Dimensions	Accessories	Material / Finish	Part No.
  	Retaining washer 	Stainless steel	991W04-1BP
	Slotted retaining washer 	Stainless steel	991W02-1BP

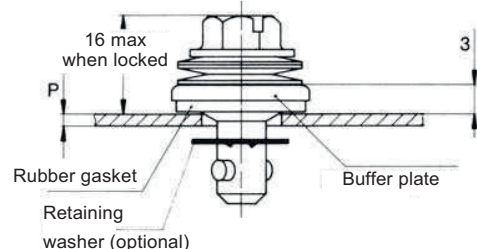
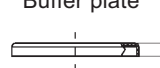
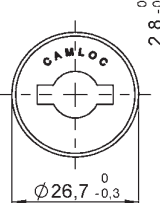
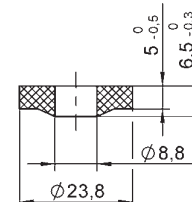
Sealed Stud Assemblies

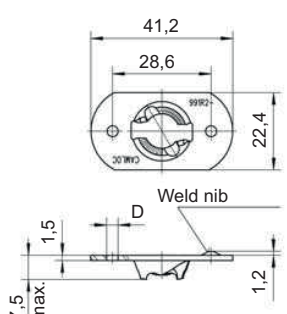
Installation Dimensions	Accessories	Material / Finish	Part No.
	Buffer plate  	Stainless steel	991W03-1BP
	Rubber gasket 	NBR black (100°C max.)	991S17-1K

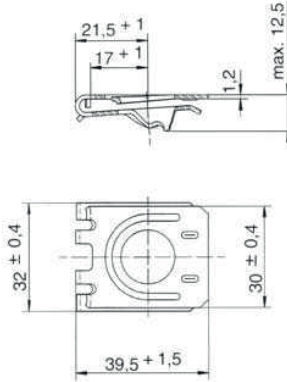
Style	Dimensions	Materials / Finish	Mounting ∅	°C	Part No.
Rivet / Screw Mounting 		Rivet / Screw Mounting Steel / zinc-plated, CrVI-free, clear passivation	3,3	120	991R2-1AGV
		Steel / zinc-plated, CrVI-free, clear passivation	4,1	120	991R2-3AGV
		Stainless steel	3,3	200	991R2-1BP
		Stainless steel	4,1	200	991R2-3BP
		Welding Steel / zinc-plated	-	-	991R2-2AZ
		Steel / oil coated	-	-	991R2-2AR
Clip-On 		Steel / zinc-plated, zinc flake coated Frame thickness F= 1,5mm - 3,5mm		150	991R6-1AK7

Receptacle Installation Instructions

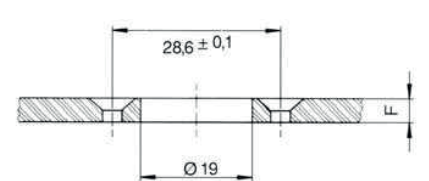
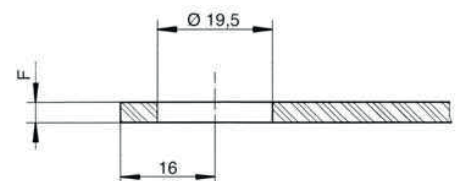
Installation Dimensions	
Rivet / Screw or Welded Mounting 	Clip-On 

Features

Max. tensile strength 4.700 N, working load 3.100 N.

Small fastener for high tensile load.

Large range of stud assemblies with fixed and floating receptacles

Selection Instructions

1. Select stud assembly, page G-4 and G-5, grommet and snap-on retaining ring, page G-7 and receptacle, page G-8 and G-9.
2. Select retaining washer, page G-6, for studs from length no. 16.
3. Select stud length number from total thickness G using the formula and the table on page G-2 and G-3 (e.g. D 4002-*AGV).

Determining the stud length number when using receptacle:

Standard version

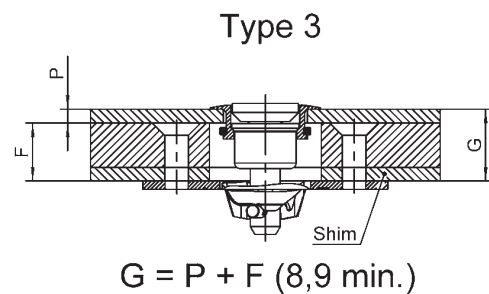
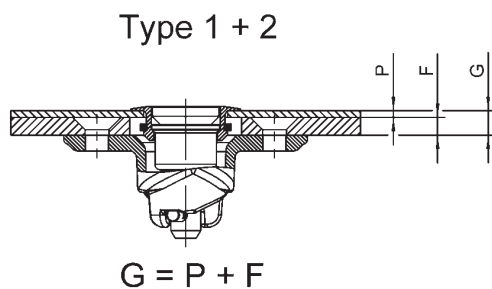

Sealed version

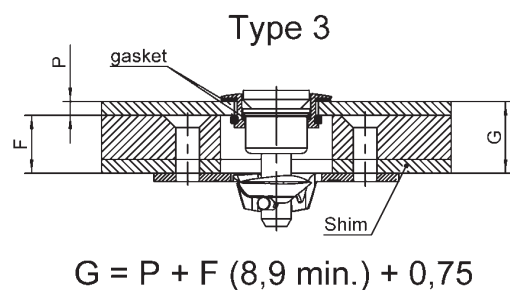
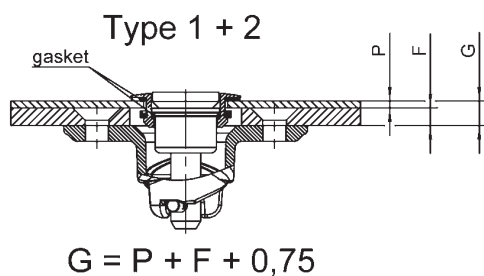

When Using the Following Grommet and Receptacles:					
Flush Mounting Grommets					
D4002-G-AGV		D4002-H-AGV			
Total Thickness G	Stud Length No. When Using Type 1 Receptacles	Total Thickness G	Stud Length No. When Using Type 2 Receptacles	Total Thickness G	Stud Length No. When Using Type 3 Receptacles
0,50 - 1,30	-	0,50 - 1,30	-	8,90 - 9,65	2
1,30 - 2,05	-	1,30 - 2,05	2	9,65 - 10,40	3
2,05 - 2,80	2	2,05 - 2,80	3	10,40 - 11,20	4
2,80 - 3,55	3	2,80 - 3,55	4	11,20 - 11,95	5
3,55 - 4,30	4	3,55 - 4,30	5	11,95 - 12,70	6
4,30 - 5,10	5	4,30 - 5,10	6	12,70 - 13,50	7
5,10 - 5,85	6	5,10 - 5,85	7	13,50 - 14,20	8
5,85 - 6,60	7	5,85 - 6,60	8	14,20 - 15,00	9
6,60 - 7,30	8	6,60 - 7,30	9	15,00 - 15,75	10
7,30 - 8,15	9	7,30 - 8,15	10	15,75 - 16,50	11
8,15 - 8,90	10	8,15 - 8,90	11	16,50 - 17,30	12
8,90 - 9,65	11	8,90 - 9,65	12	17,30 - 18,00	13
9,65 - 10,40	12	9,65 - 10,40	13	18,00 - 18,80	14
10,40 - 11,20	13	10,40 - 11,20	14	18,80 - 19,55	15
11,20 - 11,95	14	11,20 - 11,95	15	19,55 - 20,30	16
11,95 - 12,70	15	11,95 - 12,70	16	20,30 - 21,10	17
12,70 - 13,50	16	12,70 - 13,50	17	21,10 - 21,85	18
13,50 - 14,20	17	13,50 - 14,20	18	21,85 - 22,60	19
14,20 - 15,00	18	14,20 - 15,00	19	22,60 - 23,40	20
15,00 - 15,75	19	15,00 - 15,75	20	23,40 - 24,15	21
15,75 - 16,50	20	15,75 - 16,50	21	24,15 - 24,90	22
16,50 - 17,30	21	16,50 - 17,30	22	24,90 - 25,65	23
17,30 - 18,00	22	17,30 - 18,00	23	25,65 - 26,40	24
18,00 - 18,80	23	18,00 - 18,80	24	26,40 - 27,20	25
18,80 - 19,55	24	18,80 - 19,55	25	27,20 - 27,95	26
19,55 - 20,30	25	19,55 - 20,30	26	27,95 - 28,70	27
20,30 - 21,10	26	20,30 - 21,10	27	28,70 - 29,50	28
21,10 - 21,85	27	21,10 - 21,85	28	29,50 - 30,20	29
21,85 - 22,60	28	21,85 - 22,60	29	30,20 - 31,00	30
22,60 - 23,40	29	22,60 - 23,40	30	31,00 - 31,75	31
23,40 - 24,15	30	23,40 - 24,15	31	31,75 - 32,50	32
24,15 - 24,90	31	24,15 - 24,90	32	32,50 - 33,30	33
24,90 - 25,65	32	24,90 - 25,65	33	33,30 - 34,05	34
25,65 - 26,40	33	25,65 - 26,40	34	34,05 - 34,80	35
26,40 - 27,20	34	26,40 - 27,20	35		
27,20 - 27,95	35	26,40 - 27,20	35		







Other lengths on request.

■ Preferred dash-lengths

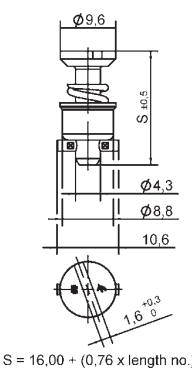

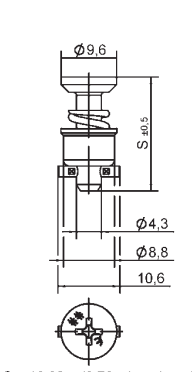

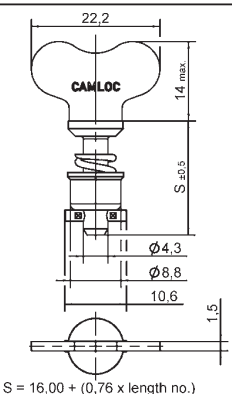
When Using the Following Grommet and Receptacles:					
Plus Flush Mounting Grommets					
D4002-N-AGV		D4002-O-AGV		D4002-R-AGV	
D4002-P-AGV		D4002-R-AGV		D4002-R-AGV	
Total Thickness G	Stud Length No. When Using Type 1 Receptacles	Total Thickness G	Stud Length No. When Using Type 2 Receptacles	Total Thickness G	Stud Length No. When Using Type 3 Receptacles
0,50 - 1,30	1	0,50 - 1,30	2	8,90 - 9,65	3
1,30 - 2,05	2	1,30 - 2,05	3	9,65 - 10,40	4
2,05 - 2,80	3	2,05 - 2,80	4	10,40 - 11,20	5
2,80 - 3,55	4	2,80 - 3,55	5	11,20 - 11,95	6
3,55 - 4,30	5	3,55 - 4,30	6	11,95 - 12,70	7
4,30 - 5,10	6	4,30 - 5,10	7	12,70 - 13,50	8
5,10 - 5,85	7	5,10 - 5,85	8	13,50 - 14,20	9
5,85 - 6,60	8	5,85 - 6,60	9	14,20 - 15,00	10
6,60 - 7,30	9	6,60 - 7,30	10	15,00 - 15,75	11
7,30 - 8,15	10	7,30 - 8,15	11	15,75 - 16,50	12
8,15 - 8,90	11	8,15 - 8,90	12	16,50 - 17,30	13
8,90 - 9,65	12	8,90 - 9,65	13	17,30 - 18,00	14
9,65 - 10,40	13	9,65 - 10,40	14	18,00 - 18,80	15
10,40 - 11,20	14	10,40 - 11,20	15	18,80 - 19,55	16
11,20 - 11,95	15	11,20 - 11,95	16	19,55 - 20,30	17
11,95 - 12,70	16	11,95 - 12,70	17	20,30 - 21,10	18
12,70 - 13,50	17	12,70 - 13,50	18	21,10 - 21,85	19
13,50 - 14,20	18	13,50 - 14,20	19	21,85 - 22,60	20
14,20 - 15,00	19	14,20 - 15,00	20	22,60 - 23,40	21
15,00 - 15,75	20	15,00 - 15,75	21	23,40 - 24,15	22
15,75 - 16,50	21	15,75 - 16,50	22	24,15 - 24,90	23
16,50 - 17,30	22	16,50 - 17,30	23	24,90 - 25,65	24
17,30 - 18,00	23	17,30 - 18,00	24	25,65 - 26,40	25
18,00 - 18,80	24	18,00 - 18,80	25	26,40 - 27,20	26
18,80 - 19,55	25	18,80 - 19,55	26	27,20 - 27,95	27
19,55 - 20,30	26	19,55 - 20,30	27	27,95 - 28,70	28
20,30 - 21,10	27	20,30 - 21,10	28	28,70 - 29,50	29
21,10 - 21,85	28	21,10 - 21,85	29	29,50 - 30,20	30
21,85 - 22,60	29	21,85 - 22,60	30	30,20 - 31,00	31
22,60 - 23,40	30	22,60 - 23,40	31	31,00 - 31,75	32
23,40 - 24,15	31	23,40 - 24,15	32	31,75 - 32,50	33
24,15 - 24,90	32	24,15 - 24,90	33	32,50 - 33,30	34
24,90 - 25,65	33	24,90 - 25,65	34	33,30 - 34,05	35
25,65 - 26,40	34	25,65 - 26,40	35		
26,40 - 27,20	35				

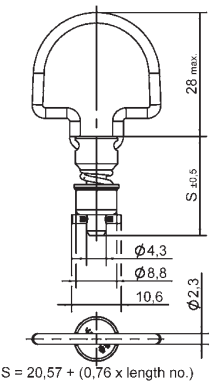
Other lengths on request.

■ Preferred dash-lengths

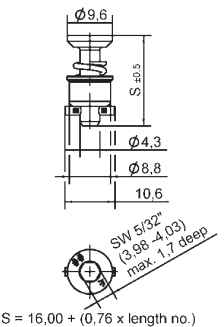

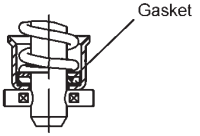
Style	Dimensions	Materials / Finish	°C	Part No.
<p>Slotted Recess Head</p> 	 <p>$S = 16,00 + (0,76 \times \text{length no.})$</p>	Steel / zinc-plated, CrVI-free, clear passivation	120	D4002-*AGV
<p>Cross Recess Head</p> 	 <p>$S = 16,00 + (0,76 \times \text{length no.})$</p>	Steel / zinc-plated CrVI-free, clear passivation	120	D40S5-*AGV
<p>Fixed Wing Head</p> 	 <p>$S = 16,00 + (0,76 \times \text{length no.})$</p>	Steel / zinc-plated, CrVI-free, clear passivation	120	D4002-*WAGV
<p>180° Folding Bail Handle</p> 	 <p>$S = 20,57 + (0,76 \times \text{length no.})$</p>	Steel / zinc-plated, CrVI-free, clear passivation	120	D40S42-*AGV

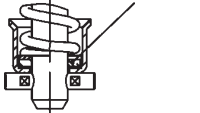

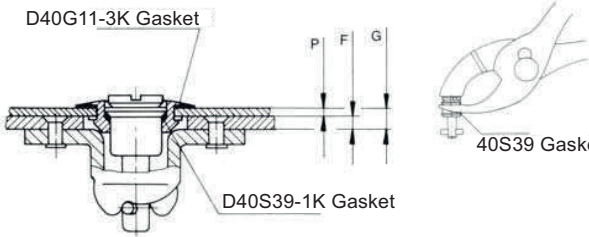
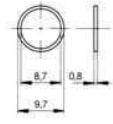
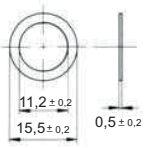



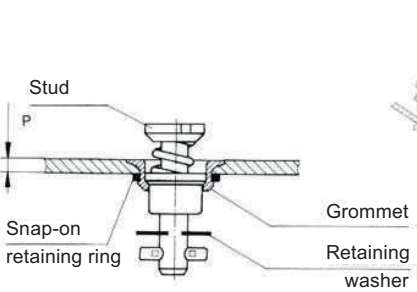
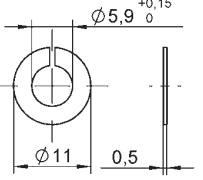
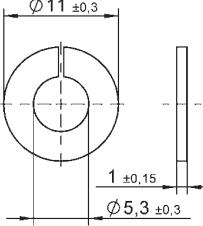

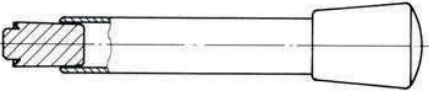
* Length no. from Table, page G-2 and G-3

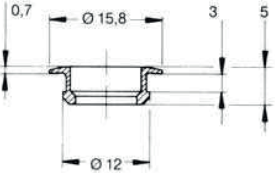
Style	Dimensions	Materials / Finish	°C	Part No.
Hex Recess Head 	 <p>S = 16,00 + (0,76 x length no.)</p>	Steel / zinc-plated, CrVI-free, clear passivation	120	D40E28- *AGV
Sealed Slotted Recess Head 	 <p>Additional required gasket see page G-4</p>	Steel / zinc-plated, CrVI-free, clear passivation Gasket: Rubber Available in Stud Length no. 4 and above	100	D4002I- *AGV
Sealed Cross Recess Head 	 <p>Additional required gasket see page G-4</p>	Steel / zinc-plated, CrVI-free, clear passivation Gasket: Rubber Available in Stud Length no. 4 and above	100	D40S5I- *AGV

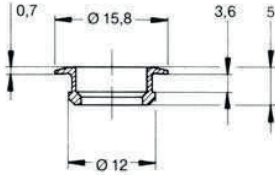
Installation Dimensions	Accessories	Materials / Finish	Part No.
<p>Gasket to be ordered in addition to the sealed stud assembly</p> 	<p>Gasket</p>  <p>Gasket</p> 	<p>Plastic / (PA6)</p> <p>EPDM black</p>	<p>D40S39-1K</p> <p>D40G11-3K</p>

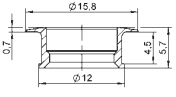

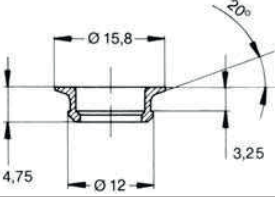

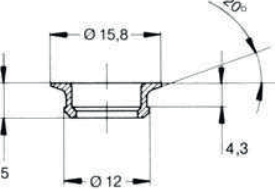
* Length no. from Table, page G-2 and G-3



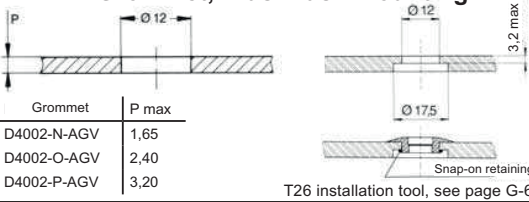
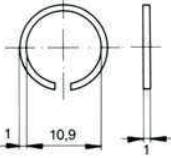
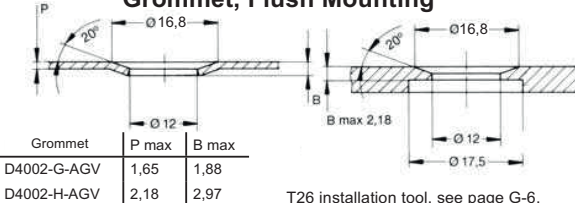

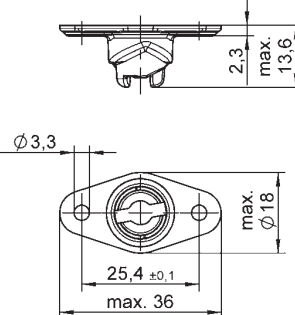
Installation Dimensions	Accessories	Materials / Finish	Part No.
 <p>4P3-1 installation pliers, see below</p>	<p>retaining ring loose on stud use for stud length no. 5 and up</p>  <p>retaining ring loose on stud use for stud length no. 5 and up</p> 	<p>Stainless steel</p> <p>Plastic</p>	<p>4002-SW-SS</p> <p>50W204-01K</p>
	<p>Stud installation pliers</p>	<p>4P3-1</p>	
	<p>R4G-* and V40G26-1N snap-on retaining ring installation tool</p>	<p>T26</p>	

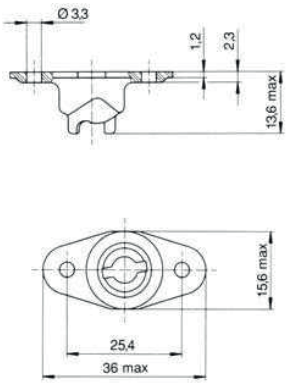
Style	Dimensions	Materials / Finish	°C	Part No.
Plus Flush Mounting For Panel Thickness up to 1,65 		Steel / zinc-plated, CrVI-free, clear passivation	120	D4002-N-AGV
Plus Flush Mounting For Panel Thickness from 1,65 to 2,40 		Steel / zinc-plated, CrVI-free, clear passivation	120	D4002-O-AGV
Plus Flush Mounting For Panel Thickness from 2,40 to 3,20 		Steel / zinc-plated, CrVI-free, clear passivation	120	D4002-P-AGV
Flush Mounting For Panel Thickness up to 1,65 		Steel / zinc-plated, CrVI-free, clear passivation	120	D4002-G-AGV
Flush Mounting For Panel Thickness from 1,65 to 2,18 		Steel / zinc-plated, CrVI-free, clear passivation	120	D4002-H-AGV

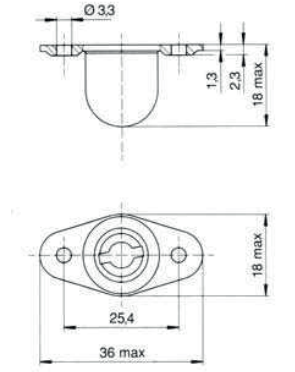
Grommets for thicker panels upon request.

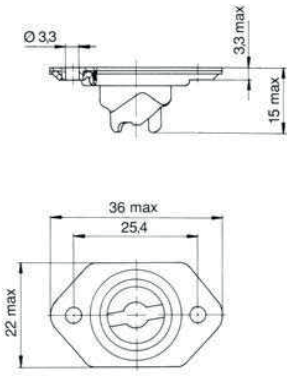
Installation Dimensions	Accessories	Materials / Finish	Part No.									
<p>Grommet, Plus Flush Mounting</p>  <table border="1"> <thead> <tr> <th>Grommet</th> <th>P max</th> </tr> </thead> <tbody> <tr> <td>D4002-N-AGV</td> <td>1,65</td> </tr> <tr> <td>D4002-O-AGV</td> <td>2,40</td> </tr> <tr> <td>D4002-P-AGV</td> <td>3,20</td> </tr> </tbody> </table> <p>T26 installation tool, see page G-6.</p>	Grommet	P max	D4002-N-AGV	1,65	D4002-O-AGV	2,40	D4002-P-AGV	3,20	<p>Snap-on retaining ring</p> 	Steel / zinc plated, CrVI-free, clear passivation	R4G-3	
Grommet	P max											
D4002-N-AGV	1,65											
D4002-O-AGV	2,40											
D4002-P-AGV	3,20											
<p>Grommet, Flush Mounting</p>  <table border="1"> <thead> <tr> <th>Grommet</th> <th>P max</th> <th>B max</th> </tr> </thead> <tbody> <tr> <td>D4002-G-AGV</td> <td>1,65</td> <td>1,88</td> </tr> <tr> <td>D4002-H-AGV</td> <td>2,18</td> <td>2,97</td> </tr> </tbody> </table> <p>T26 installation tool, see page G-6.</p>	Grommet	P max	B max	D4002-G-AGV	1,65	1,88	D4002-H-AGV	2,18	2,97			
Grommet	P max	B max										
D4002-G-AGV	1,65	1,88										
D4002-H-AGV	2,18	2,97										

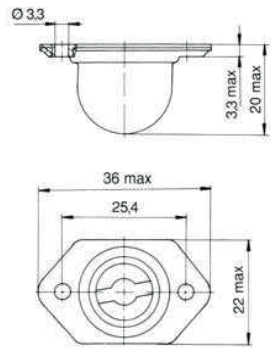
Style	Dimensions	Materials / Finish	°C	Part No.
<p>Type 1 Cast</p> 		Hard bronze / zinc-plated, CrVI-free, clear passivation	120	D214-16FGV
<p>Type 1 Cast Narrow Width</p> 		Hard bronze / zinc-plated, CrVI-free, clear passivation	120	D214-16NFGV
<p>Type 1 Cast Encapsulated</p> 		<p>Hard bronze / zinc-plated, CrVI-free, clear passivation</p> <p>Capsule: Brass / zinc-plated, CrVI-free, clear passivation</p>	150	D40R12-1FGV

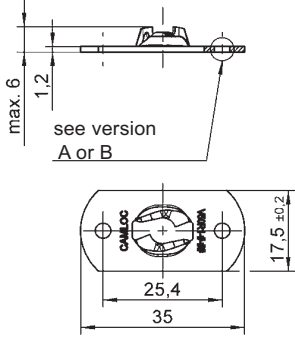
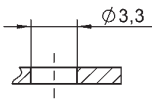
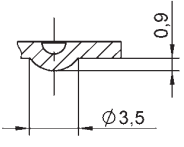
Style	Dimensions	Materials / Finish	°C	Part No.
<p>Type 2 Float up to 0,75 mm* (Cast Receptacle)</p> 		<p>Hard bronze / zinc-plated, CrVI-free, clear passivation</p> <p>Cage: Steel / zinc-plated, CrVI-free, clear passivation</p>	120	D244-16-FGV
<p>Type 2 Float up to 0,75 mm* Encapsulated</p> 		<p>Hard bronze / zinc-plated, CrVI-free, clear passivation</p> <p>Capsule: Steel / zinc-plated, CrVI-free, clear passivation</p>	120	D244-16C-FGV
<p>Type 3 Flat Rivet / Screw or Weld Mounting</p> 	 <p>Version A</p>  <p>Version B</p> 	<p>Rivet / Screw Mounting Hard bronze / zinc-plated, CrVI-free, clear passivation</p> <p>Welding Steel / zinc-plated</p>	120 -	V50R1-1-1AGV V50R1-1-2AZ V50R1-1-2AR

Installation Dimensions

Types 1, 2 and 3 Receptacle Hole Pattern



AeroLoc™ is a new quarter turn fastener, designed with our engineering partner Camloc. This new, innovative product offers designers and race engineers a modern, self eject fastening solution in both cross recess and bail handle head styles.

Benefits

- Security - stays locked in place
- Consistent performance
- Stronger and no weight penalty
- Flush fitting & quicker to operate
- More durable, longer life
- Choice of head styles

BAIL HANDLE

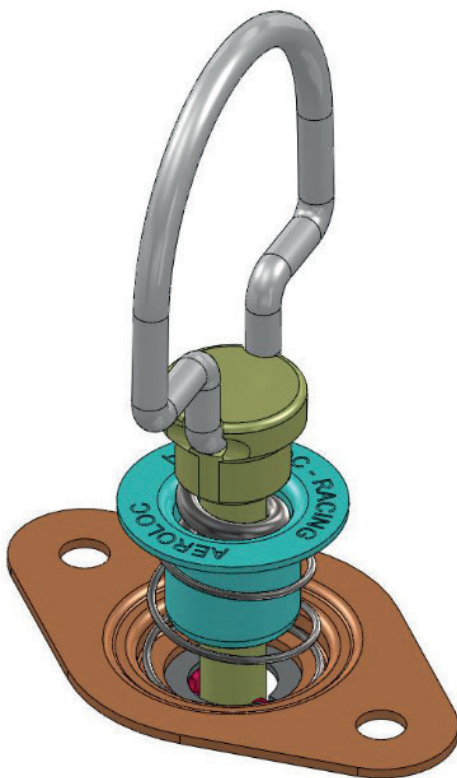

HAND OPERATED
For some installations, where use of a screwdriver is difficult, the bail handled version can be specified.

CROSS RECESS

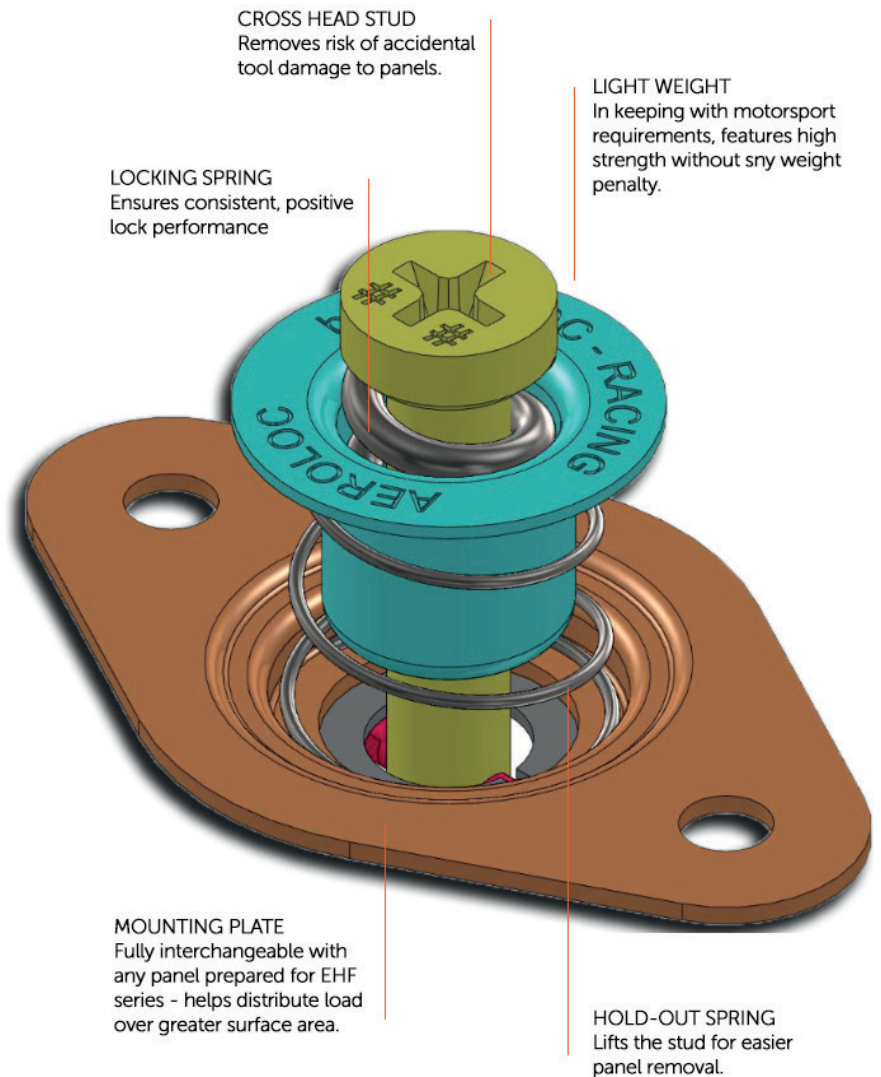

CROSS HEAD STUD
Removes risk of accidental tool damage to panels.

LOCKING SPRING
Ensures consistent, positive lock performance

LIGHT WEIGHT
In keeping with motorsport requirements, features high strength without any weight penalty.

MOUNTING PLATE
Fully interchangeable with any panel prepared for EHF series - helps distribute load over greater surface area.

HOLD-OUT SPRING
Lifts the stud for easier panel removal.

Specification

- Zinc plated steel
- Passivated and sealed
- Sizes - range of stud lengths

CAD MODELS ARE AVAILABLE UPON REQUEST

www.aeroloc.co.uk



Cross Recess version

Plan view

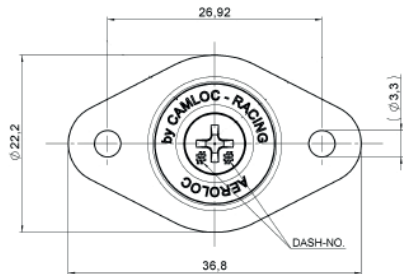

Stud assembly

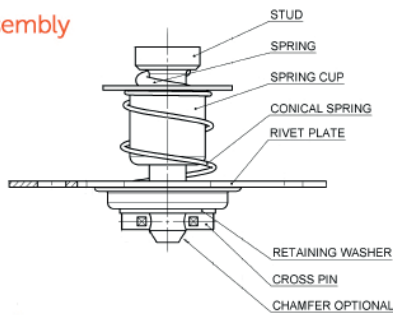

Receptacle

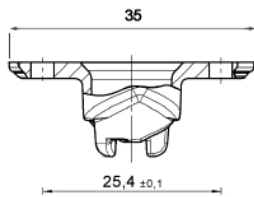

Installed

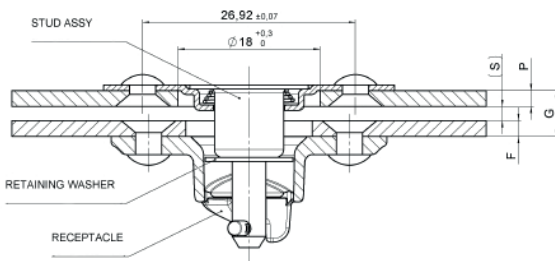

STUD PART NUMBER Cross Recess head style	STUD PART NUMBER Bail Handle head style	GRIP (mm)	
		MIN	MAX
200-1007 **	200-5007 **	3.55	4.30
200-1007 *	200-5007 *	4.30	5.10
200-1007	200-5007	5.10	5.85
200-1008	200-5008	5.85	6.60
200-1009	200-5009	6.60	7.30
200-1010	200-5010	7.30	8.15
200-1011	200-5011	8.15	8.90

Bail handle version

Plan view

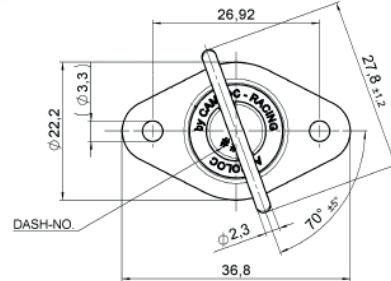

Stud assembly

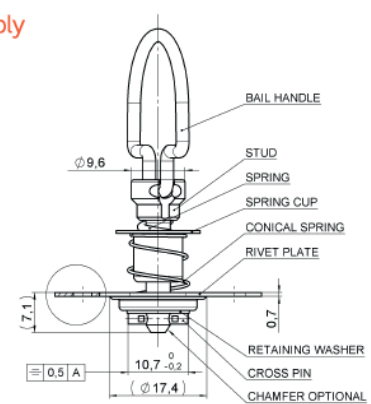

Receptacle

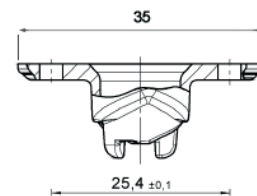

Installed

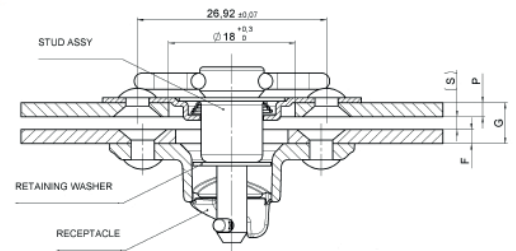

SHIM			
Use shim below where noted			
* 205-9008			
** 205-9015			
RECEPTACLE			
205-1000 (Fixed)			
205-2000 (Floating)			

CAD drawings available upon request
www.aeroloc.co.uk